



EXPERIMENTAL STUDIES ON THE DESIGN OF A STRAW MULCH PICKUP USING THE TECHNOLOGY OF GROWING POTATOES ON THE FIELD SURFACE

Roman KYRYCHENKO, Candidate of Technical Sciences, Associate Professor

Mykola BAKUM, Candidate of Technical Sciences, Associate Professor

Oleksandr LUBCHENKO, Postgraduate Student

State Biotechnological University

Oleksii MELNYK, Doctor of Agricultural Sciences, Senior Researcher

Institute of Vegetable and Melon Growing of NAAS

КИРИЧЕНКО Роман Васильович, к.т.н., доцент

БАКУМ Микола Васильович, к.т.н., доцент

ЛУБЧЕНКО Олександр, аспірант

Державний біотехнологічний університет

МЕЛЬНИК Олексій Володимирович, д.с.н., старший науковий співробітник

Інститут овочівництва і баштанництва НААН

The article presents a new design of a straw mulch picker for the technology of growing potatoes on the field surface and the results of its experimental evaluation. The relevance of the study lies in the need to improve mechanized mulch removal before harvesting while ensuring minimal damage to potato tubers. The proposed picker is equipped with curved combined guide plates with stalk lifters, which intensify lifting and separation of the mulch layer and reduce the harmful mechanical impact on tubers located near the soil surface.

The aim of the study was to determine the influence of the height of the picker drum rakes on the completeness of mulch pickup and the level of tuber damage. Experimental studies were carried out under different adjustment parameters of the working elements. The relationship between the gap value and the main quality indicators of the technological process was established.

The results showed that the optimal gap of 4.5 cm ensures the best combination of performance indicators. Under these conditions, maximum completeness of mulch pickup was achieved together with minimal damage to potato tubers. A smaller gap increases the mechanical impact on tubers, whereas a larger one reduces the efficiency of mulch removal.

The proposed technical solution is promising for improving the technology of growing potatoes on the field surface, reducing losses and minimizing tuber injury during harvesting. It also supports a resource-saving approach to production mechanization.

It was experimentally established that the gap between the elastic drum rakes and the field surface determines a trade-off between mulch pickup completeness and tuber damage, with its optimal value ensuring efficient mulch removal while minimizing mechanical impact on the crop.

Keywords: potatoes, mulch, mulch picker, stalk lifter, picker drum, tuber damage, technology of growing potatoes on the field surface.

Fig. 4. Ref. 16.

1. Problem formulation

Potato tubers are a valuable food product, rich in carbohydrates, potassium and vitamin C, which determines their high energy value and positive effect on metabolism and functioning of the main systems of the human body. According to the recommendations of nutritionists, the daily norm of potato consumption for an adult is 200-340 g.

The level of potato consumption in Ukraine is about 136-140 kg per person [1, p. 34]. At the same time, potato consumption in urban areas is traditionally lower compared to rural areas. Part of the potato harvest in rural households, primarily substandard products, is used as feed for poultry and domestic animals. In addition, in Ukraine, 80 thousand tons of potatoes are processed annually for the production of chips and 35 thousand tons are used for the production of starch [2, p. 498].





The majority of potatoes in Ukraine are grown in households, on homesteads and summer cottages, and in small farms. However, since the beginning of hostilities, there has been a trend towards a reduction in the volume of potato cultivation in households, which is due to the high labor intensity of technological operations and a shortage of labor.

Potatoes are among the crops that are demanding on temperature and moisture. Lowering the temperature to negative values during night frosts leads to damage and death of plants, while increasing the temperature above 25°C slows down plant growth and can cause the so-called ecological degeneration. At air temperatures above 27-29°C, tuber formation when grown by traditional methods is significantly inhibited, which negatively affects the yield and quality of products [3].

The most favorable conditions for the formation of a high potato yield are created when the soil moisture is at the level of 75-85% of the lowest moisture capacity. A decrease in this indicator, especially in critical phases of plant development, leads to a sharp decrease in yield and marketability of products. At the same time, excessive soil moisture can lead to a decrease in the content of dry matter and starch in tubers. Under such conditions, tubers are more intensively affected by fungal and bacterial diseases, which worsens their keeping quality during storage [4].

One of the effective ways to ensure optimal temperature and water balance is the use of covering and mulching materials of organic and inorganic origin (straw of cereal crops, mowed grass, tree leaves, bark of coniferous species, polymeric materials, film, etc.). The use of mulch contributes to the improvement of the temperature and physical properties of the arable soil layer, the formation of a favorable microclimate in crops and an increase in the yield of agricultural crops, in particular potatoes, as well as a decrease in the energy intensity of their cultivation technologies [5-7].

Therefore, in the context of modern climate change and labor shortages, improving potato growing technologies aimed at increasing yield stability, creating optimal soil and climatic conditions, and reducing the labor intensity of production is of particular relevance.

2. Analysis of recent research and publications

One of the promising directions for increasing the efficiency of vegetable growing technologies is the use of mulching materials of organic and inorganic origin (cereal straw, mowed grass, tree leaves, coniferous bark, polymeric materials, film, etc.). The use of mulch contributes to the improvement of the temperature and physical properties of the arable soil layer, the formation of a favorable microclimate in crops, an increase in the yield of agricultural crops, in particular potatoes, and a decrease in the energy intensity of their cultivation technologies [5-10]. It has been established that a layer of straw 20-25 cm thick ensures the maintenance of the soil temperature in the zone of tuber formation and growth at 16-20 °C even with an increase in daytime air temperature to 30-35 °C. In addition, the mulching layer of straw significantly reduces the evaporation of moisture from the soil surface. Due to the difference in daily temperatures under the mulch layer, condensation occurs in the form of water droplets, which contributes to additional soil moisture.

Studies also show that with significant daily temperature fluctuations, the relative humidity of the air above the mulch layer changes almost threefold, while under the mulch layer its fluctuations are much smaller - from 90.2% to 70%. With sunset, the humidity of the air under the mulch layer increases faster than above the straw surface, which creates more favorable conditions for the growth and development of potato plants [11-14].

At the same time, the issue of mechanization of potato cultivation on the surface of the field under the mulch layer, in particular the creation of technical means for effective collection of mulch during harvesting, requires further research [15].

3. The purpose of the article

The purpose of the article is to substantiate the design of a straw mulch layer picker for the technology of growing potatoes on the soil surface, experimentally verify the efficiency of its operation, and determine the completeness of mulch pick-up and the level of damage to potato tubers.

4. Results and discussion

Modern mechanized potato growing technologies provide the necessary soil conditions for germination and the formation of high yields only under favorable weather conditions. They are based on the accumulation of moisture in the autumn-winter-spring period and high-quality soil cultivation without its losses when performing all operations - from peeling stubble to inter-row cultivation of crops at optimal times

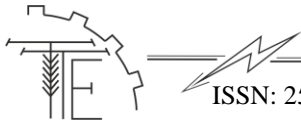

in compliance with agrotechnical requirements. The implementation of such technologies requires modern machine complexes and material and technical support, which is still insufficient for most farms in Ukraine. Forced simplification of technologies leads to a decrease in yield and production efficiency, which partly explains the low interest of agricultural companies in growing potatoes. In recent years, production risks have also increased due to changes in weather conditions, especially temperature.

Potato cultivation has become widespread in recent years, especially in homestead farms using a new method: growing potatoes on the surface of the field under a layer of mulch.

Potatoes are planted on the surface of the field with this method of cultivation without digging into the soil at an earlier time, when the surface of the field dries out. In this case, soil cultivation, with the exception of early spring harrowing, is not performed.

Planted tubers are covered with a layer of straw 20–25 cm thick, which allows potato sprouts to germinate, but suppresses weeds. The soil under the mulch does not dry out and does not become crusted, so care is reduced only to protecting plants from diseases and pests by spraying with fungicides and insecticides.

The roots of potatoes planted on the surface of the field penetrate the soil, ensuring the growth of shoots and stolons, from which new tubers are formed, mainly on the surface under a layer of mulch.

Harvesting includes removing mulch from crops, short-term drying (1–2 hours) and picking up tubers with existing potato diggers or combines with a depth of up to 5 cm, which increases the productivity of machines and reduces energy consumption and damage to potatoes.

This method is widely used in summer cottages, provides high yields even in dry years without the use of tillage tools and even additional irrigation. To use this method on large areas of sowing, effective machines for removing mulch from potato crops are required.

Rakes of various designs (transverse, wheel-finger, rotary, etc.), which are used for raking hay and straw, can be used to pick up the layer of potato mulch, but this leads to damage to the tubers and their partial fall into the windrows.

The use of existing designs of pickers (header pickers, balers, pickers-hoes, etc.) can significantly increase the completeness of mulch collection, but damage to tubers increases significantly. Damage to tubers by pickers can be reduced by using stem lifters, which are equipped with combine harvester headers.

The use of stem lifters on combine harvesters reduces injuries, but part of the mulch falls off due to loss of elasticity when the drum is raised. However, due to a slight change in the angle of elevation of the upper bar of the stem lifters, the mulch layer remains in a raised state for a long time and, due to the loss of its elastic properties, a significant part of it falls off onto the field surface. This significantly reduces the completeness of mulch collection from potato crops, which complicates its harvesting.

The design of the potato mulch layer picker is based on a serial baler (Fig. 1), in which the swath is picked up by elastic drum tines, fed by curved guides to the cross conveyor and the baling chamber. Such a picker allows you to press the mulch for transportation, lay it in swaths on an already harvested field, or sow it on the field for the next year.

To reduce mulch shedding, a special stalk lifter with curved guide plates has been proposed. Its working surface has an intensive increase in the angle of elevation to the area of grip capture, which reduces the movement of the raised mulch and improves the quality of picking without damaging the tubers. The proposed design of a mulch picker from potato rows (Fig. 1, a), which is grown on the surface of the field, consists of a frame with support wheels 1, on which are hinged sidewalls 2 with a picker drum with elastic rakes 3, between which are fixed curved combined guide plates 4 (Fig. 1, b). The picker drum on the sidewalls 2 is fixed perpendicular to the direction of movement of the picker, its height position is regulated by a copying roller 5 with an adjustment mechanism 6, fixed on the sidewall 2.

The curved combined guide plate 4 consists of a support and copying surface 7, a stem lifter 8 and an upper guide part 9, stiffening ribs 10 and holes 11 for fastening the plates 4 to the drum body (Fig. 1, c).

Behind the combined guide plates 4 of the pick-up drum 3, a transverse conveyor 12 is installed, which feeds the picked-up mulch to the device 13 for forming a swath or bales and laying them next to the potato rows using a guide tray 14 and a frame 15. The mulch pick-up is aggregated with the tractor using a trailer hitch 16. The working bodies are driven from the tractor's power take-off shaft using drive mechanisms 17.

Before starting work, the pick-up is adjusted to the specified operating conditions. Depending on the width of the rows and the width of the potato bushes on the pick-up drum with elastic tines 3, the curved plates are replaced with combined guide plates 4 so that during operation they move in the row and do not catch the tubers (if the potato tubers are buried in the soil (certain potato varieties), then all combined guide plates 4 are



installed on the pick-up drum). The height of the drum is adjusted using a copying roller so that the supporting and copying surfaces of the guide plates are above the field surface.

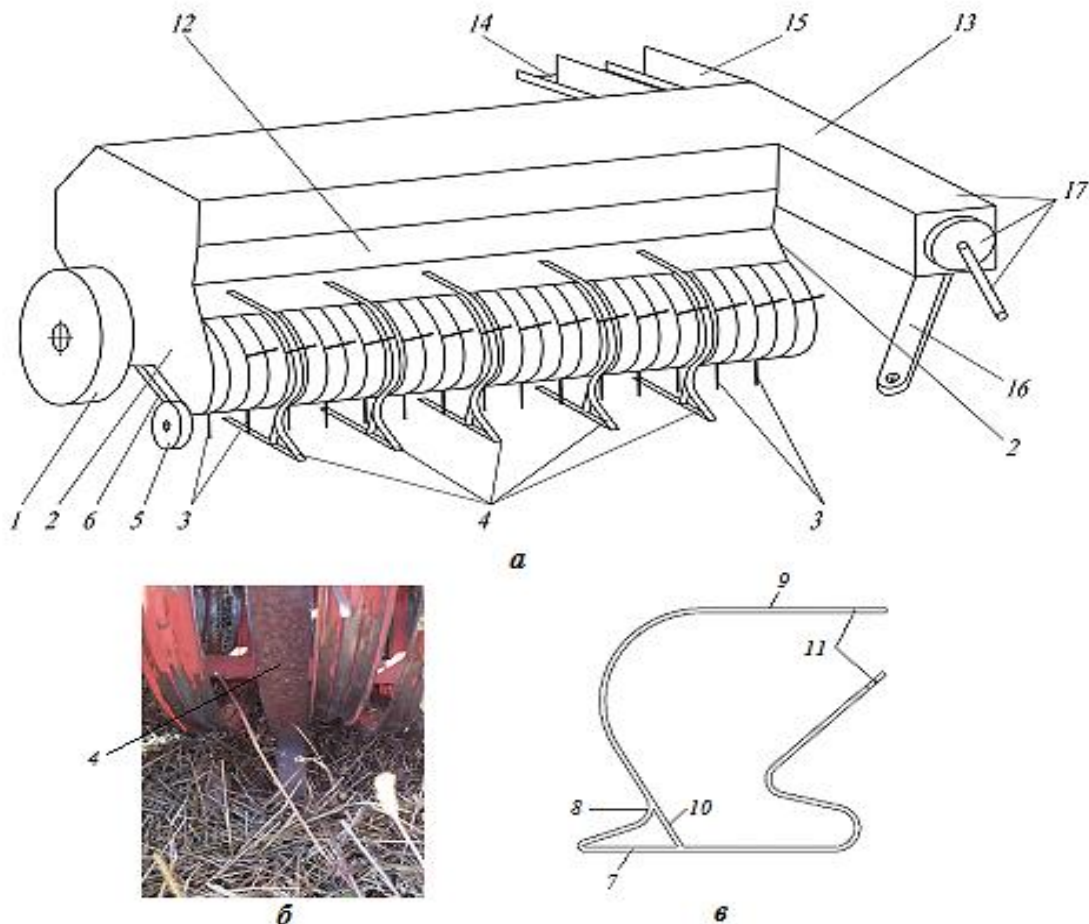

Fig. 1. Mulch collector from potato rows:

a – structural diagram of the potato row mulch picker; *b* – general view of the curved combined guide plate; *c* – structure of the curved combined guide plate; 1 – frame with support wheels; 2 – sidewalls; 3 – pick-up drum with elastic tines; 4 – curved combined guide plates; 5 – copying roller; 6 – adjustment mechanism; 7 – supporting and copying surface of the guide plate; 8 – stalk lifter; 9 – upper guide of the guide plate; 10 – stiffening rib; 11 – holes; 12 – cross conveyor; 13 – device for forming a windrow or bales; 14 – guiding tray; 15 – frame; 16 – trailer nose; 17 – drive mechanism

During operation, the picker drives into the rows (while the tractor moves across the harvested field), the drive 17 is turned on and the picker drum with tines 3 is lowered. The stalk lifters 8 of the combined guide plates 4, moving along the surface of the field, lift the mulch layer, which is captured by the elastic tines of the picker drum 3 and transfer the mulch to the transverse conveyor 12.

The design of the front surface of the stalk lifter 8 of the combined guide plates 4 in the form of a logarithmic spiral provides an intensive increase in the mulch lifting angle, which significantly reduces the contact time of the mulch layer with the soil, and hence its residues on the field surface. The transverse conveyor 12 feeds the mulch to the device 13 for forming a swath or bales, which are stacked next to the rows of potatoes.

The unit that picks up the potatoes, which are now open and on the surface of the field, passes behind the mulch picker.

Thus, by installing combined guide plates 4 on the pick-up drum between the tines 3, the lower part of which is a stalk lifter 8, the frontal surface of which is made in the form of a logarithmic spiral, it provides a more complete lifting of mulch from potato crops with minimal mechanical damage to the tubers. To assess the efficiency of the pick-up with the proposed stalk lifters, field studies were conducted in the conditions of the "Zamiske" farm on potato crops planted on the surface of the field (Fig. 2).

At the time of harvest, most of the potato tubers were on the surface of the field, while small and some medium-sized tubers were in the soil at a depth of up to 5 cm. Wheat straw was used as mulching material, which was laid in a layer 20–25 cm thick in a loosened state. At the time of harvest, the thickness of the mulch layer was 15–20 cm, and the average weight of straw per 1 m² – 3,885 kg. There were no gaps or gaps in the mulch layer, which prevented the germination of weeds, so the crops remained relatively clean.

The air temperature during the day and night periods varied significantly, which was accompanied by condensation of moisture on the surface of the field and in the lower layers of the mulch cover. As a result, the moisture content of the mulch layer was uneven, and the lower layer was more humid, which complicated the process of picking up the mulch.

Before the start of the experiment, four curved combined guide plates with stem lifters of the proposed design were installed on the pick-up drum instead of standard guide plates, located at the same distance from each other. The height h of the elastic rakes of the pick-up drum above the field surface was adjusted using an adjustment mechanism from 1 to 11 cm with an interval of 2 cm. The speed of movement of the unit during the study was set at 3 km/h and remained constant throughout the experiment. After the pick-up passes, the field is freed from mulch, while rows of potatoes located on the soil surface remain on the surface (Fig. 3).



Fig. 2. Potato bushes under a layer of mulch before harvesting



Fig. 3. Field surface after mulching

During the experiment, the efficiency of the picker with the proposed stalk lifters was evaluated by determining two indicators: the amount of straw M_{3c} , that remained on the field surface, as a percentage of the initial mass of the mulch layer and the proportion of damaged potato tubers $\Pi_{н.к.3б}$ as a percentage of the actual harvest.

The amount of mulch on a 1 m² plot was determined in three replicates. The mulch residues were collected manually and weighed separately for each replicate. Potato tubers on the same plots were also collected manually and sorted into two fractions: intact and damaged. The percentage of damaged tubers was determined by weight. The results of the studies are shown in Figure 4.

Analysis of the obtained data showed that the size of the gap between the elastic rakes of the drum and the field surface significantly affects both the damage to potato tubers located on the surface and the completeness of mulch collection from crops. With an increase in the height of the rakes, the amount of mulch residues on the field surface increases proportionally. Even with a minimum gap of 1 cm, mulch collection was not complete due to increased humidity, greater layer compaction and loss of elastic properties of straw, which led to its crushing and shedding under the action of the rotation of the rakes of the drum.

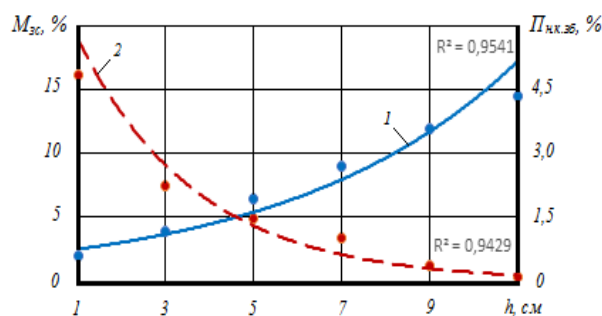
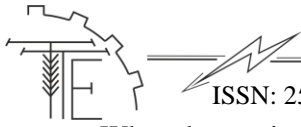

Fig. 4. Dependence of the completeness of mulch collection and damage to potato tubers on the height of the rakes of the collecting drum: 1 – completeness of mulch collection; 2 – damage to potato tubers



When the gap increased by more than 5 cm, the mulch residues on the surface increased significantly, which negatively affected the conditions for further harvesting of tubers. At the same time, with an increase in the gap between the field surface and the drum tines, the level of tuber damage decreased, which is explained by a decrease in the intensity of contact of the elastic tines with the tubers. The results of the studies showed that the amount of tuber damage at all studied gap values did not exceed 5%, which is significantly lower than the permissible level of potato damage during harvesting, which is 12% [16, p. 365]. In most cases, the damage was manifested only in the form of peeled skin due to the mechanical action of the elastic tines.

It should be noted that the results of the experiment were significantly influenced by the level of potato yield, the ability of tubers to detach from the stems, and the depth of tubers in the soil during their formation. Tubers located on the surface were at greater risk of mechanical damage, while some small and medium tubers buried up to 5 cm into the soil remained protected from direct contact with the rakes, which reduced their injury.

According to the results of the experiments, it was found that under the studied conditions, the maximum completeness of straw mulch collection with minimal damage to potato tubers of 1.5% is achieved with a gap between the rakes of the collecting drum and the field surface of 4.5 cm.

5. Conclusion

1. A design of the picker stalk lifter has been developed, which ensures effective lifting of the mulch layer from the field surface when growing potatoes on the soil surface without significant mechanical damage.

2. The completeness of mulch collection depends on the height of the rakes of the picker drum relative to the field surface. With an increase in the gap between the rakes and the soil surface, the completeness of mulch collection decreases, but at the same time the level of damage to potato tubers decreases.

3. An increase in the gap between the field surface and the rakes of the picker drum contributes to a decrease in the contact of the elastic rakes with the tubers, which ensures a decrease in their mechanical damage. According to the results of the studies, it was found that tuber damage in the entire studied range did not exceed 5%, which is significantly lower than the permissible indicator of 12% during mechanized potato harvesting.

4. Under the studied conditions, with a gap between the rakes of the pick-up drum and the field surface of 4.5 cm, the maximum completeness of straw mulch collection is achieved with minimal damage to potato tubers.

5. The proposed design of the mulch pick-up can be used in the technology of growing potatoes on the field surface for mechanized removal of mulch material before harvesting the main crop.

References

1. Spaskyi, H. V., & Trutenko, H. O. (2021). Analysis of production and consumption of vegetables and potatoes in the regions of Ukraine. *Ekonomika APK*, 7, 28–37. <https://doi.org/10.32317/2221-1055.202107028> [in Ukrainian].
2. Onopriienko, I. M. (2016). State and prospects of regional potato growing development. *Global and National Problems of Economy*, 497–500. [in Ukrainian].
3. Muraviov, V. O., Melnyk, O. V., Dukhina, N. H., Semybratska, T. V., & Uriupina, L. M. (2020). Potato cultivation in the Eastern Forest-Steppe of Ukraine: recommendations. Vinnytsia: Tvory. [in Ukrainian].
4. Melnyk, O. V. (2023). Cultivation of food and seed potatoes in the Eastern Forest-Steppe of Ukraine. Vinnytsia: Tvory. [in Ukrainian].
5. Palamarchuk, I. I. (2013). Productivity and fruiting dynamics of zucchini under soil mulching in the Right-Bank Forest-Steppe. *Vegetable and Melon Growing*, 59, 226–234. [in Ukrainian].
6. Zribi, W., Aragüés, R., Medina, E., & Faci, J. M. (2015). Efficiency of inorganic and organic mulching materials for soil evaporation control. *Soil and Tillage Research*, 148, 40–45. <https://doi.org/10.1016/j.still.2014.12.003> [in English].
7. Kader, M. A., Senge, M., Mojid, M. A., & Nakamura, K. (2017). Mulching type-induced soil moisture and temperature regimes and water use efficiency of soybean under rain-fed conditions in central Japan. *International Soil and Water Conservation Research*, 5(4), 302–308. <https://doi.org/10.1016/j.iswcr.2017.08.001> [in English].
8. Pastukhov, V. I., Bakum, M. V., Viskham, A. I., et al. (2016). Substantiation of potato cultivation technology on the field surface under a straw layer. *Bulletin of KhNTUSG named after P. Vasylenko. Mechanization of Agricultural Production*, 173, 5–13. [in Ukrainian].



9. Pastukhov, V. I., Kyrychenko, R. V., Bakum, M. V., et al. (2020). Substantiation of potato cultivation using Strip-Till technology. *Engineering of Nature Management*, 2(16), 25–32. [https://doi.org/10.37700/enm.2020.2\(16\).25-32](https://doi.org/10.37700/enm.2020.2(16).25-32) [in Ukrainian].
10. Pastukhov, V., Mogilnay, O., Bakum, M., Melnyk, O., et al. (2020). Energy-efficient and ecologically friendly technology for growing potatoes under straw mulch. *Ukrainian Journal of Ecology*, 10(1), 317–324. https://doi.org/10.15421/2020_50 [in English].
11. Goel, L., Shankar, V., & Sharma, R. K. (2019). Investigations on effectiveness of wheat and rice straw mulches on moisture retention in potato crop. *International Journal of Recycling of Organic Waste in Agriculture*, 8(Suppl. 1), 345–356. <https://doi.org/10.1007/s40093-019-00307-6> [in English].
12. Pastukhov, V. I., Mogilna, O. M., Melnyk, O. V., Kyrychenko, R. V., & Bakum, M. V. (2020). Study of agrophons as a factor influencing potato cultivation on the field surface under straw mulch. In *Theoretical and practical aspects of vegetable growing development in modern conditions: Proceedings of the III International Scientific and Practical Conference* (Vol. 2, pp. 137–139). Vinnytsia: Tvory. [in Ukrainian].
13. Pastukhov, V., Mogilnay, O., Bakum, M., Grabar, I., et al. (2021). Potato growth in moisture deficit conditions. *Ukrainian Journal of Ecology*, 11(2), 184–190. https://doi.org/10.15421/2021_97. [in English].
14. Melnyk, O., et al. (2023). Study of the effectiveness of different methods of mulching potatoes (*Solanum tuberosum*) in the east of Ukraine. *Agronomy Research*, 21(3), 1221–1232. <https://doi.org/10.15159/AR.23.057> [in English].
15. Pastukhov, V. I., Kyrychenko, R. V., Bakum, M. V., & Lubchenko, O. V. (2024). Substantiation of improvement of machines for potato cultivation. In *Scientific Week in Kruty – 2024. Proceedings of the X International Scientific and Practical Conference* (Vol. 2, pp. 185–188). Vinnytsia. [in Ukrainian].
16. Bondarchuk, A. A., & Koltunov, V. A. (Eds.). (2019). *Potato growing: methodology of research*. Vinnytsia: Tvory. [in Ukrainian].

ЕКСПЕРИМЕНТАЛЬНІ ДОСЛІДЖЕННЯ КОНСТРУКЦІЇ ПІДБИРАЧА СОЛОМ'ЯНОЇ МУЛЬЧІ ДЛЯ ТЕХНОЛОГІЇ ВИРОЩУВАННЯ КАРТОПЛІ НА ПОВЕРХНІ ПОЛЯ

У статті представлено нову конструкцію підбирача солом'яної мульчі для технології вирощування картоплі на поверхні поля та результати її експериментальної оцінки. Актуальність дослідження зумовлена необхідністю вдосконалення механізованого видалення мульчі перед збиранням урожаю за одночасного забезпечення мінімального пошкодження бульб картоплі. Запропонований підбирач оснащено вигнутими комбінованими напрямними пластинами зі стеблонідіймачами, які інтенсифікують піднімання й відокремлення шару мульчі та зменшують шкідливий механічний вплив на бульби, розташовані поблизу поверхні ґрунту.

Метою дослідження було визначення впливу висоти розташування граблин барабана підбирача на повноту підбирання мульчі та рівень пошкодження бульб. Експериментальні дослідження проводили за різних регульовальних параметрів робочих органів. Установлено залежність між величиною зазору та основними якісними показниками технологічного процесу.

Результати показали, що оптимальний зазор 4,5 см забезпечує найкраще поєднання показників ефективності. За таких умов досягнуто максимальної повноти підбирання мульчі одночасно з мінімальним пошкодженням бульб картоплі. Меньший зазор підвищує механічний вплив на бульби, тоді як більший знижує ефективність видалення мульчі.

Запропоноване технічне рішення є перспективним для вдосконалення технології вирощування картоплі на поверхні поля, зменшення втрат і мінімізації пошкодження бульб під час збирання урожаю. Воно також відповідає ресурсоощадному підходу до механізації виробництва.

Експериментально встановлено, що зазор між пружними граблинами барабана підбирача та поверхнею поля визначає компроміс між повнотою підбирання мульчі та рівнем пошкодження бульб, при цьому його оптимальне значення забезпечує ефективне видалення мульчі з мінімальним механічним впливом на врожай.

Ключові слова: картопля, мульча, підбирач мульчі, стеблонідіймач, барабан підбирача, пошкодження бульб, технологія вирощування картоплі на поверхні поля.

Рис. 4. Літ 16.

**INFORMATION ABOUT THE AUTHORS**

Roman KYRYCHENKO – Candidate of Technical Sciences, Associate Professor of the Department of Agricultural Engineering of the State Biotechnological University (44 Alchevskikh St., Kharkiv, Ukraine, 61002, e-mail: kirichenkoromeo@btu.kharkov.ua, <https://orcid.org/0000-0001-7830-6956>).

Mykola BAKUM – Candidate of Technical Sciences, Associate Professor of the Department of Agricultural Engineering of the State Biotechnological University (44 Alchevskikh St., Kharkiv, Ukraine, 61002, e-mail: bakymshm@btu.kharkov.ua, <https://orcid.org/0000-0003-1049-0464>).

Oleksandr LUBCHENKO – Postgraduate Student of the Department of Agricultural Engineering of the State Biotechnological University (44 Alchevskikh St., Kharkiv, Ukraine, 61002, e-mail: madman13sd@gmail.com, <https://orcid.org/0009-0000-2948-0704>).

Oleksii MELNYK – Doctor of Agricultural Sciences, Senior Researcher, Head of the Department of Advanced Technologies for Growing Vegetable and Melon Crops at the Institute of Vegetable and Melon Growing of the NAAS (1, Instytutська St., Seleksiynе Village, Kharkiv Region, Ukraine, 62478, e-mail: melnyk.iob@gmail.com, <https://orcid.org/0000-0002-0965-6116>).

КИРИЧЕНКО Роман Васильович – кандидат технічних наук, доцент кафедри агроінженерії Державного біотехнологічного університету (вул. Алчевських, 44, м. Харків, Україна, 61002, e-mail: kirichenkoromeo@btu.kharkov.ua, <https://orcid.org/0000-0001-7830-6956>).

БАКУМ Микола Васильович – кандидат технічних наук, доцент кафедри агроінженерії Державного біотехнологічного університету (вул. Алчевських, 44, м. Харків, Україна, 61002, e-mail: bakymshm@btu.kharkov.ua, <https://orcid.org/0000-0003-1049-0464>).

ЛУБЧЕНКО Олександр Вадимович – аспірант кафедри агроінженерії Державного біотехнологічного університету (вул. Алчевських, 44, м. Харків, Україна, 61002, e-mail: madman13sd@gmail.com, <https://orcid.org/0009-0000-2948-0704>).

МЕЛЬНИК Олексій Володимирович – доктор сільськогосподарських наук, старший науковий співробітник, завідувач відділу перспективних технологій вирощування овочевих і баштанних культур Інституту овочівництва і баштанництва НААН (вул. Інститутська, 1, сел. Селекційне, Харківська область, Україна, 62478, e-mail: melnyk.iob@gmail.com, <https://orcid.org/0000-0002-0965-6116>).