

DEVELOPMENT OF METHODOLOGY AND TOOLS FOR EXPERIMENTAL RESEARCH OF THE PROCESS OF REMOVING TOPS FROM ROOT CROP HEADS USING NEW WORKING ORGANS

Andrii BORYS, Candidate of Technical Sciences, Senior Researcher

Institute of Mechanics and Automation of Agro-Industrial Production of the National Academy of Agrarian Sciences of Ukraine

Oleksandra TROKHANIAK, Candidate of Technical Sciences, Associate Professor

National University of Life and Environmental Sciences of Ukraine

Viktor PRYSYAZHNYI, Candidate of Technical Sciences, Senior Researcher

Institute of Mechanics and Automation of Agro-Industrial Production of the National Academy of Agrarian Sciences of Ukraine

БОРИС Андрій Миколайович, к.т.н., старший науковий співробітник

Інститут механіки та автоматики агропромислового виробництва Національної академії аграрних наук України

ТРОХАНЯК Олександра Миколаївна, к.т.н., доцент

Національний університет біоресурсів і природокористування України

ПРИСЯЖНИЙ Віктор Григорович, к.т.н., старший науковий співробітник

Інститут механіки та автоматики агропромислового виробництва Національної академії аграрних наук України

An analysis was carried out of the methods and technical means used to study the process of separating tops and their residues from root crop heads by experimental working bodies. It was established that most existing approaches are focused on field testing, which is labor-intensive and does not always allow the isolated influence of structural, technological and agrophysical factors to be determined. Therefore, the development of a laboratory methodology for studying new working bodies is a relevant scientific and practical task.

A laboratory setup and research procedure were developed to investigate the interaction between working bodies and sugar beet roots with different agrophysical parameters. The proposed design enables modeling of the main crop characteristics: height of root head protrusion above the soil surface, deviation of the root from the row axis, spacing between adjacent roots, root dimensions and top characteristics. The setup also makes it possible to vary the parameters of rotary working bodies, including rotor diameter, length and number of working elements, angle of inclination, angle of attack and rotational frequency.

The methodology includes fixation of natural root crops in the "moving field" frame, adjustment of operating modes, high-speed video recording and registration of quality indicators after treatment. The recorded parameters make it possible to assess root crop damage, cutting height and direction, quality of the cut surface, degree of top separation and losses of sugar-bearing mass. The obtained data are processed statistically using average values, standard deviation and coefficient of variation. The developed setup reduces the labor intensity of studies and creates a basis for substantiating rational parameters of working bodies.

Keywords: root crop, root crop head, tops, working organ, parameters, laboratory setup, research methodology.

Eq. 5. Fig. 4. Tab. 3. Ref. 11.

1. Problem formulation

The efficient harvesting of sugar beet largely depends on the quality of tops removal and root crop head cleaning processes. Modern beet-harvesting machines employ various rotary working bodies for cutting, removing, and cleaning tops; however, the effectiveness of these operations is significantly influenced by the design parameters and operating modes of the working elements. Inappropriate selection of these parameters may result in excessive losses of sugar-bearing mass, insufficient cleaning of root crop heads, increased damage to root crops, and deterioration of harvesting quality indicators.



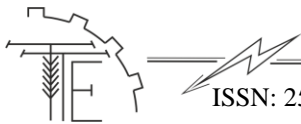

The development of new working bodies for tops removal requires comprehensive experimental investigations aimed at determining rational design and technological parameters, as well as validating theoretical models of the technological process. Traditionally, such studies are conducted under field conditions, which are characterized by considerable labor intensity, high material costs, dependence on weather and soil conditions, and limited possibilities for the controlled variation of individual factors affecting the process. These limitations significantly complicate the evaluation of the influence of specific design parameters on the quality and efficiency of tops removal.

At the same time, an analysis of existing research reveals the absence of universal laboratory installations and scientifically substantiated methodologies for investigating the processes of removing the main mass of tops and cleaning root crop heads from top residues. Therefore, the development of a specialized laboratory installation and an appropriate experimental methodology for studying the operation of rotary working bodies under controlled conditions represents an important scientific and practical task. Such an approach would enable a more accurate evaluation of the influence of structural and technological parameters on the quality of tops separation while reducing the complexity, duration, and cost of experimental investigations.

2. Analysis of recent research and publications

In order to determine the design of a laboratory setup for studying the process of separating the top, it is necessary to determine the main types of operations and working bodies used in the process of preparing root crops for digging. Analyzing the works of L.V. Pogoriliy, V.M. Bulgakov, R.B. Hevko, V.Ya. Martynenko, M.M. Helemendik, S.V. Syny, E.I. Ignatyev and others, it was established that at the present stage, the following operations can be performed when removing the top:

- separation of the main mass of the top by cutting the top on the growing root crop or by the impact action of flexible working elements (defoliation);
- eliminating the harmful effect of tops on the technological process of harvesting root crops by: crushing tops and distributing them in rows and between rows or only between rows; transporting tops to a vehicle or to the harvested field;
- separation of the tops by trimming or cleaning the heads of root crops.

Each of the above operations corresponds to a certain type of working body. The cutting of the main mass of the tops can be carried out with copying the heads of root crops or without copying them by cutting at a fixed height relative to the soil surface. Rotors with horizontal, vertical or inclined axes of rotation to the horizon are mainly used for cutting [1-4]. The removal of tops by impact interactions is carried out using defoliators - rotors with flexible elements. The distribution of tops in the rows is carried out simultaneously with the processes of cutting and grinding by using guiding surfaces in the casing of the cutting rotor. The practice of pressing plant residues into the soil in the rows is also known. For transporting tops, augers, bar conveyors or a set of vertical augers are mainly used. The removal of plant residues from the row spacing is carried out using the fan effect in rotary top cutters with a horizontal axis of rotation. Cleaning of root crop heads from the remains of the top is carried out by rotors with flexible working elements - cleaners. The most common of them are blade cleaners [5, 6].

Thus, for operations of separating the tops and its remains, rotary working elements are mainly used, which are characterized by a change in such structural and technological parameters as: rotor diameter, working element fixing radius, working element orientation relative to the direction of translational movement of the machine, fixing and installing the working element to the rotor rotation plane, etc..

Let us consider the methods and means of experimental research used in the study of the process of removing the tops. As a rule, all studies are characterized by:

- manufacturing an experimental laboratory-field installation, conducting experimental research using experimental planning methods in order to substantiate the parameters and operating modes of working bodies;
- conducting comparative tests of the proposed and existing working bodies in terms of productivity, energy consumption and work quality indicators in terms of the content of tops in the root crop heap, the degree of cleaning from tops, losses of sugar-bearing mass, damage to root crops, knocking out root crops from the soil, etc.

The methodology for assessing the quality of work has been developed for field tests of working bodies, but there is no methodology for laboratory research. The assessment of the quality of the work of beet-removing working bodies in Western European countries is regulated by the Eurostandard, and in Ukraine by DSTU 7062:2009 "Sugar beets. Harvesting. Quality indicators and methods for their assessment" and

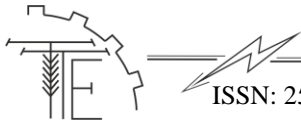

DSTU 2258-93 “Beet harvesting machines. General technical conditions”. Quality indicators according to the Eurostandard are determined by the location of the cut plane on the root crop head and the type of cut of the root crop head, and according to DSTU 7062:2009 and DSTU 2258-93 – by losses of sugar-bearing mass, the content of beet tops in the head of root crops and damage to root crops. The methodology developed at the Institute of Biotechnology of the Ukrainian Academy of Sciences [7-11], which covers the methods of the above standards, is more universal..

Thus, at the present stage there are no designs of universal installations and methods of laboratory research of working bodies for separation of the main mass and the remains of the tip. In addition, in laboratory conditions, it is possible to more accurately identify the influence of individual factors on the technological process of separation of the tops.

3. The purpose of the article

The purpose of the article is Reducing the labor intensity and expanding the scope of experiments is necessary by developing the design of the installation and the methodology for laboratory research of working bodies for separating the main mass and the remains of the tip. The design of the laboratory installation must provide for:

- modeling of agrophysical characteristics of sugar beet crops;
- the possibility of using natural root crops with different agrophysical parameters in research;
- changes in a wide range of design and technological parameters and operating modes of rotary-type working elements.

4. Results and discussion

Development of the design of the installation and the methodology for laboratory research of the working elements for the separation of the main mass and the remains of the tip includes:

- initial requirements for the process of separating the tops;
- agrophysical parameters of root crops and crops, the modeling of which is possible in laboratory conditions;
- laboratory setup, modeling of the initial parameters of experimental studies;
- experimental methodology;
- analysis of experimental data.

We will develop the initial requirements for the process of separating the tops based on DSTU 2258 - 93, DSTU 7062:2009, Eurostandard and the methodology developed at the Institute of Biotechnology of the UAAN:

Main quality indicators of the tops separation process:

- the number of tied tops on root crops is no more than 1.5%;
- normally cut root crops are no less than 85%;
- low cut root crops are no more than 5%;
- severe mechanical damage to root crops is no more than 5%;
- general damage to root crops is no more than 20%;
- loss of sugar-bearing mass is no more than 2%;
- the cut of the head should be straight, smooth, without chips and the cut plane should pass no lower than the level of the base of the green leaves and no higher than 20 mm from the top of the root head.

Significant damage to root crops – damage with a depth of more than 10 mm and chips up to a third of the root crop. Minor damage to root crops – damage with a depth of less than 10 mm or a torn cut with a torn depth of no more than 10 mm. Normal cut – a cut of the root head not lower than the base of the green leaves and not higher than 20 mm above the apical bud. High cut – a cut of the root above the apical bud. Low cut – a cut of the root head below the base of the green leaves. The cut surface of the root crop is called smooth in the case of a smooth and even surface, or with chips and depressions less than 10 mm deep. Root crops with a chipped cut surface – root crops with a stepped cut surface, with the presence of depressions and cracks more than 10 mm deep. Root vegetables with an oblique cut - root crops with a cut plane deviated from the normal to the longitudinal axis of the root crop by an angle of more than 100. Root vegetables with a straight cut - root crops with a cut plane perpendicular to the longitudinal axis or with a deviation from its normal by an angle of less than 100.

Agrophysical parameters of root crops and crops, the modeling of which is possible in laboratory conditions. In laboratory conditions, it is possible to simulate the following agrophysical characteristics of

crops: the height of the root crop head above the soil level, the deviation of the root crop from the conditional axis line of the row, the distance between the root crops in the row. We plan to conduct experimental studies using natural root crops with different agrophysical parameters. The main dimensional characteristics of the root crop are determined according to Fig. 1.

When measuring, it is necessary to take into account the features of determining the following indicators. The height of the top is the distance from the soil surface to the tops of the main number of leaf blades. The height of the cut part of the top is the distance from the top of the head to the cut plane. The diameter of the top bundle is the thickness of the pre-compressed top bundle at a distance of 50 mm from the base of the green leaves. The angle of taper of the top is the maximum value of the angle of the top cone, which is formed by the extreme petioles of the majority of the top. The angle of taper of the top and the root crop head are measured with special goniometers in the vertical plane.

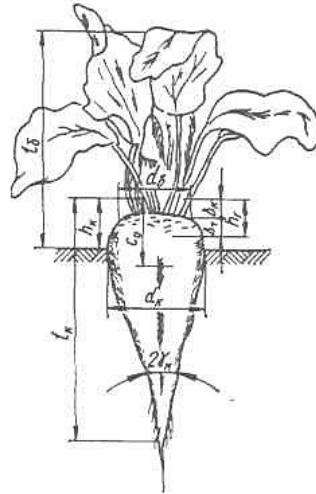
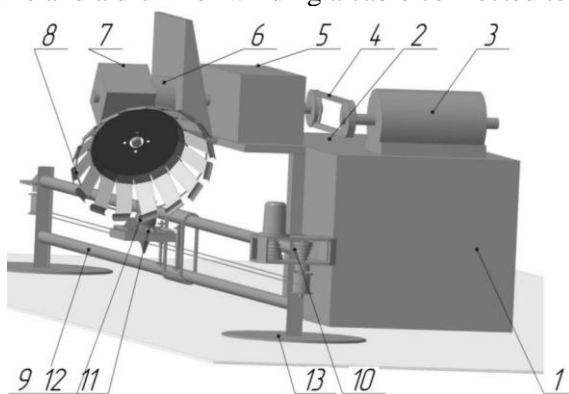

Fig. 1. Agrophysical parameters of sugar beet root crops:

l_δ – height of the top; d_δ – diameter of the top bundle; h_κ – height of the root head protrusion above the soil level; $\Delta\kappa$ – thickness of the green leaf zone; Δm – thickness of the dormant eye zone; h_2 – height of the head; C – coordinate of the center of mass of the root crop; d_κ – maximum diameter of the root crop; l_κ – technical length of the root crop; γ_κ – angle of taper of the lower part of the root crop

Laboratory setup, modeling of initial parameters of experimental studies. We have developed and manufactured a laboratory setup (Fig. 2), which provides the possibility of modeling operating modes and structural and technological parameters of working bodies, as well as agrophysical characteristics of crops and root crop parameters.

The laboratory setup for studying the top-removing working bodies consists of the main frame 1 (Fig. 2), electric motor 3, V-belt transmission 4, chain-plate variator 5, rotary device 6, bevel gear 7 and working body 8 fixed on its shaft, “moving field” frame 9 (Fig. 3), “moving field” frame drive mechanism 10, moving field frame 11, root crop 12, racks 13. The “moving field” frame drive mechanism consists of an electric motor frame and a drum for winding a cable connected to frame 11.



a



b

Fig. 2. Laboratory installation for researching working bodies:
a – structural diagram; *b* – general view of the installation

*a**b*

Fig. 3. Fixing the root crop in the frame of the “moving field”:
a – device diagram; b – general view of the “moving field” frame with the root crop fixed

A feature of the design is the ability to change the following parameters: rotational speed, translational speed of its movement of the rotor, the angle of inclination of the rotor to the horizon, the angle of attack of the rotor, the distance between the root crops in the row, the deviation of the root crop from the conditional axis line of the row, the height of the protrusion of the root crop head above the conditional soil surface, etc. To study the influence of the mutual arrangement of the root crops, a variable frame is provided for fixing three root crops that may have different size and mass characteristics. The engine control scheme 2 provides for a reversible mode of movement. The drives of the rotor with working bodies and the “moving field” are controlled from the control box.

Agrophysical characteristics of crops are determined according to Fig. 4. Taking into account the fact that in all rotors in real conditions the lower points are located at the soil surface level, we determine for laboratory conditions:

- the height of the root crop above the soil level h_k as the distance from the horizontal plane passing through the lowest point of the rotor to the top of the root crop head fixed in the holder (Fig. 4, b);
- deviation of the root crop from the center line of the row δ as the distance between parallel straight lines mn and kc . The straight line mn passes in a horizontal plane corresponding to the soil surface level through the point of contact with the rotor of the working body parallel to the direction of movement of the root crop (Fig. 4, b). The straight line kc passes in a horizontal plane corresponding to the soil level through the axis of symmetry of the root crop parallel to the direction of its movement.

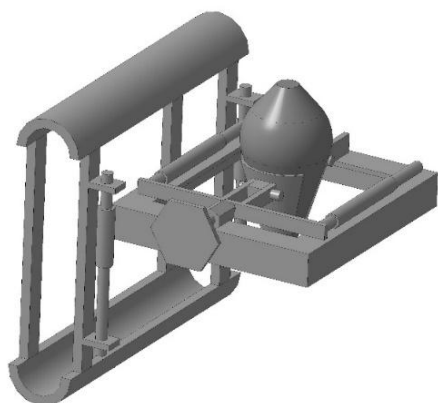
The height of the root crop head protrusion is regulated by moving the root crop holder along the vertical guides of the moving field frame using a screw mechanism (Fig. 3). The deviation of the root crop from the conditional center line of the row is regulated by parallel movement of the moving field together with the racks 12 along the support surface.

In order to study the influence of mutual arrangement of root crops on the process of tops separation, a variable platform for group arrangement of three root crops is installed on the frame of the “moving field”. The distance between the roots is the distance between the centers of two adjacent root crops. It is regulated by rigidly fixing the roots at different distances from each other.

The design and technological parameters of the working body were determined according to the schemes shown in Fig. 4, b, c. The angle of attack α is the angle between the line of intersection of the plane of rotation with the soil surface level fg and the axial line of the row kc or the direction of movement of the working body relative to the root crop on. It is set by rotating the moving field on the support surface around the vertical axis passing through the lower point of the rotor. It was determined by the scale applied to the support surface and the pointer on the moving field. The angle of inclination of the rotor to the horizontal plane β is the angle between the lines oe and oi , which are formed as a result of the intersection of the vertical plane passing through the axis of the rotor drive shaft, the rotor rotation plane and the soil level plane, respectively. The angle β is set by rotating the rotor around the axis of the drive shaft of the bevel gearbox using the rotary mechanism 6 (Fig. 2). The angle of inclination of the rotor is measured using a scale installed on the rotary mechanism. The rotor diameter, the length of the working elements, the number of working elements, and the initial angle of deviation of the working elements from the radial position were determined according to Fig. 4, c.



The operating modes of the tops separation process were determined before and during the experiment. The translational speed of the working body was determined as follows. A special scale was applied to the frame of the moving field, near the working body zone, and an indicator was applied to the frame of the moving field. When the moving field drive was turned on, high-speed video recording of the process began. By using frame-by-frame viewing of the video material, the position of the indicator on the scale was fixed, which corresponded to the beginning and end of the interaction of the working body with the root crop, and then the movement was determined.

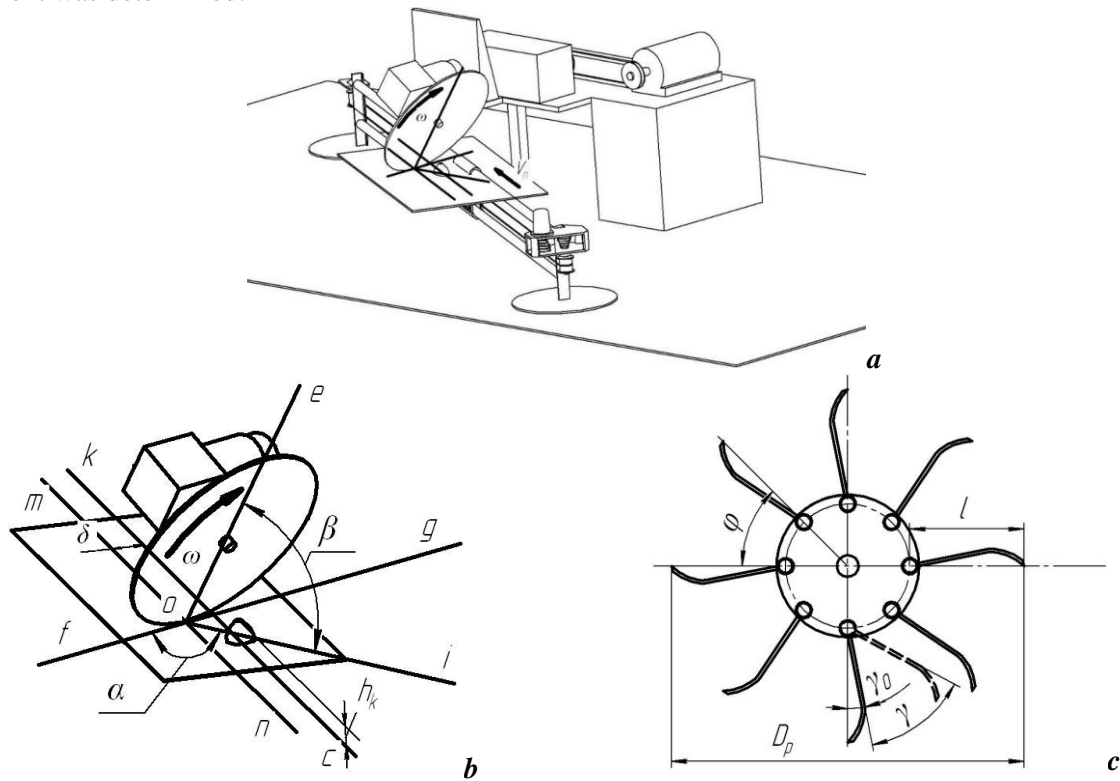
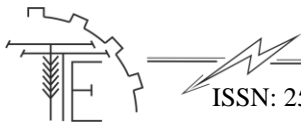

Fig. 4. Scheme for determining the initial parameters of the process of interaction of working bodies with root crops:
a – general case of installing the rotor of the working body in relation to the row of root crops;
b and c – schemes for determining the design and technological parameters of the working body and agrophysical parameters of crops

Taking into account the frequency of high-speed video recording (210; 420; 1000 frames/s), the duration of interaction was determined by the number of frames in which the contact of the working body with the root crop was recorded. The average speed of translational movement of the root crop before or after interaction was determined by the movement and time of interaction. The translational speed of the root crop was regulated by installing variable pulleys of different diameters in the drive of the moving field. The average value of the angular velocity was determined similarly by the angle of rotation of the rotor and the time of interaction. The frequency of rotation of the rotor was smoothly regulated using a chain-plate variator.

For laboratory studies, natural root crops with a top were used. Due to the rapid loss of turgor, the roots were dug up immediately before the experiment. Before digging up, the height of the root head protrusion above the soil level was measured. Then the root crop with a top was dug up, cleaned of soil residues and the tail was cut to a diameter of 10 mm. On the lateral surface of the root crop, its protrusion height above the soil level was marked by making holes with a diameter of 3...4 mm and a depth of 5...10 mm. One hole corresponded to a protrusion height of 10 mm. Agrophysical parameters of root crops and tops were determined immediately before the studies according to Fig. 3 and entered in Table 1. The number of dry and green petioles was counted, the thickness of the zones of green leaves and dormant buds was measured according to Fig. 1 using a special device. The maximum diameter of the root crop was determined as the maximum thickening of the root crop. The mass of the root crop with the top was weighed using electronic scales from SOEHNLE ULTRA 2.0 with an accuracy of 0.1 g.

The research using the laboratory setup was carried out as follows. The root crop was selected according to the required height of the protrusion above the soil level, fixed with clamps at the appropriate



height in the movable frame, which was in the initial position on frame 5 (Fig. 2). The deviation of the root crop from the center line of the row, the distance between the roots, the rotation frequency and the translational speed of the root crop were determined. The values of the structural and technological parameters of the working body, the operating modes were entered in Table 1. When installing a variable platform for group placement of three root crops on the frame of the “moving field”, the value of the distance indicator between the root crops was recorded in Table 1 for the second and third, in the direction of movement, root crops. The lighting equipment was turned on. The drive of the working bodies was turned on. After that, the video recording of the interaction process and the drive of the “moving field” were turned on. The drive of the moving field and working elements was switched off automatically, using a limit switch.

The process was recorded and the indicators of the interaction of the working body with the root crop were determined. When conducting laboratory studies, the process was observed using high-speed video recording with a Casio Exilim EX-FH20 digital camera. When conducting the experiment, the parameters shown in Table 2 were recorded. The presence of such qualities as the type of damage, a certain cut height, the type of cut surface and the cut direction was noted in the corresponding cell of the table for each root crop with the number one, the absence of the indicator - with the number zero. This is necessary to calculate the number of root crops with the corresponding parameters using the program for processing the results of the experiments.

After carrying out the measurements given in Table 2, the criteria for assessing the quality of work and the characteristics of the movement of the working body were determined. When choosing the optimization criteria, the possibility and accuracy of determining the parameter with any changes in the technological process mode were taken into account.

Table 1.

Initial parameters of root crops and working organs for separating tops

| Indicator name | | Repetition (serial number of the root crop) | | | | | |
|---|--|---|---|---|---|---|---|
| | | 1 | 2 | 3 | 4 | 5 | 6 |
| Agrophysical characteristics of root crops and tops | 1. The height of the ridge, m | | | | | | |
| | 2. Height of the cut part of the branch, m | | | | | | |
| | 7. Diameter of the bundle of branches, m | | | | | | |
| | 9. Thickness of the green leaf zone, m | | | | | | |
| | 10. Thickness of the dormant cell zone, m | | | | | | |
| | 11. Head height, m | | | | | | |
| | 12. Maximum diameter of root crop, m | | | | | | |
| | 3. Tip taper angle, degree | | | | | | |
| | 4. Head taper angle, degree | | | | | | |
| | 8. Head taper angle, degree | | | | | | |
| | 5. Number of green stalks, pcs. | | | | | | |
| | 6. Number of dry petioles, pcs. | | | | | | |
| | 13. Weight of root crop with top, kg | | | | | | |
| "Field" parameters | 14. Deviation of the root crop from the row axis, m | | | | | | |
| | 15. Height of root crop head above soil surface, m | | | | | | |
| | 16. Distance between root crops (to the previous root crop), m | | | | | | |
| Design and techn | 17. Type of working body | | | | | | |
| | 18. Type of working element | | | | | | |



| | | | | | | | |
|-----------------|--|--|--|--|--|--|--|
| | 19. Rotor diameter, | | | | | | |
| | 20. Length of the working element | | | | | | |
| | 21. Number of working elements | | | | | | |
| | 22. Initial angle of deviation of the working element from the radial position | | | | | | |
| | 23. Angle of inclination to the horizontal plane | | | | | | |
| | 24. Angle of attack | | | | | | |
| | Other design parameters | | | | | | |
| Operating modes | 25. Translational speed of the working body | | | | | | |
| | 26. Rotor rotation frequency | | | | | | |

Table 2.

Parameters of the root crop, working organ and process recorded during the experiment

| Indicator name | | Repetition (serial number of the root crop) | | | | | |
|--|---|---|---|---|---|---|---|
| | | 1 | 2 | 3 | 4 | 5 | 6 |
| Agrophysical parameters of root crops and tops after interaction with the working body | 1. Root crop damage: severe; weak. | | | | | | |
| | 2. Cut height: normal; low; high | | | | | | |
| | 3. Cut surface: smooth chipped | | | | | | |
| | 4. Cutting direction: straight; oblique | | | | | | |
| | 5. Height of the top after cutting, m | | | | | | |
| | 6. Length of uncut lateral cuttings | | | | | | |
| | 7. Number of green stalks, pcs. | | | | | | |
| | 8. Number of dry petioles, pcs. | | | | | | |
| | 9. Thickness of the green leaf zone, m | | | | | | |
| | 10. Thickness of the cut layer of the green leaf zone, m | | | | | | |
| | 11. Thickness of the dormant cell zone, m | | | | | | |
| | 12. Thickness of the cut layer of the dormant cell zone, m | | | | | | |
| | 13. Head cutting height, m | | | | | | |
| | 14. Weight of root crop with top, kg | | | | | | |
| | 15. Weight of root crop without top, kg | | | | | | |
| | 16. Mass of the tip residues, kg | | | | | | |
| | 17. Mass of cut tip, kg | | | | | | |
| Indicators of movement of the working body | 18. Amplitude of oscillations of the working element, degree | | | | | | |
| | 19. Duration of 1/4 period of the fundamental form of natural oscillations, s | | | | | | |
| | 20. Period of natural oscillations, s | | | | | | |
| | 21. Frequency of natural oscillations, s ⁻¹ | | | | | | |
| | 22. Time of interaction of the working body with the root crop, s | | | | | | |
| | 23. Movement of the root crop during interaction, m | | | | | | |
| | 24. Average translational speed of the working body, m/s | | | | | | |
| | 25. Rotor rotation angle during interaction, degree | | | | | | |
| | 26. Average angular velocity of the rotor, rad/s | | | | | | |

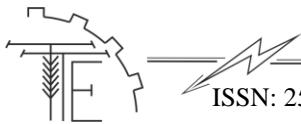

Mathematical processing of the obtained results included preliminary processing of experimental data, in-depth statistical analysis of the process and processing of the results of a multifactorial experiment. Preliminary processing of experimental data was carried out using a program developed by the authors for calculating process indicators and basic statistical characteristics using Excel tables based on Tables 1, 2 and 3. In-depth processing of statistical data was carried out using standard software. Standard experimental planning methods were used to conduct multifactorial experiments.

Mathematical processing of the obtained results included preliminary processing of experimental data, in-depth statistical analysis of the process and processing of the results of a multifactorial experiment. Preliminary processing of experimental data was carried out using a program developed by the authors for calculating process indicators and basic statistical characteristics using Excel tables based on Tables 1, 2 and 3. In-depth processing of statistical data was carried out using standard software. Standard experimental planning methods were used to conduct multifactorial experiments.

The measurement data were directly entered into the computer in the research journal (Tables 1 and 2) where all indicators were automatically calculated. At the same time, the value of the accuracy indicator of the experiment was monitored. and when it fell into the range from 1 to 5%, the experiment was stopped. In this way, the number of necessary measurements was determined.

During the preliminary processing of the experimental data, the average value was determined:

$$\bar{x} = \sum x_i / N, \tag{1}$$

where N – number of measurements.

The magnitude of the dispersion of sample values around their mean value () characterized by the standard deviation, was determined from the dependence:

$$\sigma = \sqrt{(\sum(x_i - \bar{x})^2 / N)}, \tag{2}$$

Based on the calculated values the error of the sample mean was calculated:

$$m = \sigma / \sqrt{N}, \tag{3}$$

To determine the degree of variation of the studied indicator, the coefficient of variation was determined:

$$v = (\sigma / \bar{x}) \cdot 100\%, \tag{4}$$

The experimental accuracy indicator K was determined by the formula:

$$K = (m / \bar{x}) \cdot 100\% \tag{5}$$

The analysis of indicators and criteria of the process of interaction of working bodies with root crops and tops was carried out by studying individual tabular data for each root crop and by the average indicators of the experiment presented in the form of tables and graphical dependencies.

Table 3.

Evaluation criteria and performance indicators

| Indicator name | | Main statistical indicators | | | | |
|--|---|-----------------------------|--------------------------|--------------------|--------------------------|--------------------|
| | | Average value | Mathematical expectation | Standard deviation | Coefficient of variation | Experimental error |
| Agrophysical criteria for quality assessment | 1. Number of damaged root crops, %: significantly; slightly | | | | | |
| | 2. Number of root crops cut, %: normal; low; high | | | | | |
| | 3. Number of root crops with cut surface, %: smooth chipped | | | | | |
| | 4. Number of root crops by cutting direction: straight; oblique | | | | | |



| | | | | | | | |
|--|---|---|--|--|--|--|--|
| | 5. Height of the cut of the tip, m | | | | | | |
| | 6. Length of uncut lateral cuttings, m | | | | | | |
| | 7. Degree of separation of green stalks, pcs. | | | | | | |
| | 8. Degree of separation of dry petioles, pcs. | | | | | | |
| | 9. Thickness of the cut layer of green leaves, % | | | | | | |
| | 10. Thickness of the cut layer of dormant cells, % | | | | | | |
| | 11. Head cutting height, m | | | | | | |
| | 12. Amount of tied tops on root crops, % | | | | | | |
| | 13. Loss of sugar mass, % | | | | | | |
| | Characteristics of the movement of the working body | 14. Amplitude of oscillations of the working element, degree | | | | | |
| | | 15. Period of natural oscillations, s | | | | | |
| | | 16. Frequency of natural oscillations, s ⁻¹ | | | | | |
| | | 17. Time of interaction of the working body with the root crop, s | | | | | |
| 18. Average translational speed of the working body, m/s | | | | | | | |
| 19. Average angular velocity of the rotor, rad/s | | | | | | | |

After the interaction of the working organs with the root crop, the place of contact, the quality of the separation of the top, as well as the nature and depth of the damage were determined. The dynamics of the interaction of the working organ with the root crop was analyzed by viewing the video recording of the process on the monitor..

The nature of the interaction of the working elements with the root crop was analyzed: the serial number of the interacting element; the place of entry of the working element into contact, the nature of the impact, sliding along the surface of the head, the place of exit from contact, deformation of the working organ or deviation of the rigid working organ from the initial position in different phases of contact and after exiting contact; observation and determination of the main forms, period and natural frequency of oscillations of the working organ or element, etc..

By analyzing a whole group of indicators, rational values of parameters were determined or the reason for their deviations from the normative ones was established, and conclusions were drawn about possible ways to improve the working bodies and the process..

5. Conclusion

An analysis of existing methods and technical means for studying the process of removing tops from sugar beet root crops showed that experimental investigations are predominantly carried out under field conditions, which are characterized by high labor intensity, significant material costs, and limited possibilities for controlled variation of agrophysical and technological factors.

A laboratory installation for studying the processes of removing the main mass of tops and cleaning root crop heads from top residues has been developed. The proposed design enables simulation of the principal agrophysical characteristics of sugar beet crops, including the height of root crop protrusion above the soil surface, deviation of root crops from the row axis, and spacing between adjacent root crops, as well as variation of structural and technological parameters and operating modes of rotary working bodies.

A comprehensive methodology for experimental investigations has been developed, including determination of initial agrophysical parameters of root crops, registration of kinematic characteristics of working bodies using high-speed video recording, evaluation of quality indicators of top removal, and statistical processing of experimental data. The proposed methodology expands the possibilities of laboratory research and provides reliable determination of the influence of design parameters and operating modes on the efficiency and quality of the top removal process.

The developed laboratory installation and research methodology create the basis for further experimental substantiation and optimization of new working bodies intended for removing tops and cleaning sugar beet root crop heads, while significantly reducing the labor intensity and cost of experimental studies.

References

1. Bulgakov, V. M. (2005). *Theory of beet harvesting machines*. Kyiv: NAU Publishing Center. [in English].



2. Pogorelyi, L. V., & Tatianko, N. V. (2004). *Beet harvesting machines: History, design, and outlook*. Kyiv: Phoenix. [in English].
3. Adamchuk, V., Bulgakov, V., Holovach, I., & Ignatiev, Y. (2018). Experimental research on vibrational digging-up of sugar beet. *Agricultural Science and Practice*, 5(1), 30–41. <https://doi.org/10.15407/agrisp5.01.030> [in English].
4. Kondratiuk, A., Šarauskis, E., Sheludchenko, B., Kukharets, S., Jasinskas, A., Zabrodskiyi, P., & Shubenko, V. (2024). Substantiation of the use of a flexible chain-type subsoiler for improving the agrotechnological properties of soil. *Sustainability*, 16(13), 5355. <https://doi.org/10.3390/su16135355> [in English].
5. Qiang, X., Sun, J., & Ning, H. (2022). Impact of subsoiling on cultivated horizon construction and grain yield of winter wheat in the North China Plain. *Agriculture*, 12(2), 236. <https://doi.org/10.3390/agriculture12020236> [in English].
6. Skoblo, T., Rybalko, I., Nanka, O., & Saychuk, O. (2021). Evaluation of the wear of the duckfoot sweep cultivator blades and the technology of their hardening. *Problems of Tribology*, 26(2), 6–18. <https://doi.org/10.31891/2079-1372-2021-100-2-6-18> [in English].
7. Irgashve, A., & Tulaganova, L. (2024). Wear resistance of self-sharpening blades of the tillage cultivator pointed tines. *BIO Web of Conferences*, 105, 01008. <https://doi.org/10.1051/bioconf/202410501008> [in English].
8. Lyashenko, S., & Chornobai, O. (2025). Study of the nature of changes in energy and qualitative indicators of the work of cultivator pointed tines with various degrees of wear on their blade edges. *Engineering, Energy, Transport in Agriculture*, 2(129), 79–87. <https://doi.org/10.37128/2520-6168-2025-2-10> [in English].
9. Okunskyi, O. O., Tsyon, O. P., Tsyon, H. B., Leshchuk, R. Ya., & Yuriev, O. A. (2024). Justification of the design parameters of a top-cutting trimmer with an active blade. *Central Ukrainian Scientific Bulletin. Technical Sciences*, 10(41), 186–191. [https://doi.org/10.32515/2664-262X.2024.10\(41\).1.186-191](https://doi.org/10.32515/2664-262X.2024.10(41).1.186-191) [in English].
10. Babii, A., Dovbush, T., Khomuk, N., Dovbush, A., Tson, A., & Oleksyuk, V. (2022). Mathematical model of a loaded supporting frame of a solid fertilizers distributor. *Procedia Structural Integrity*, 36, 203–210. <https://doi.org/10.1016/j.prostr.2022.01.025> [in English].
11. Bulgakov, V., Ivanovs, S., Adamchuk, V., & Smolinskyi, S. (2018). Theoretical studies of interaction of the drum cleaner with the sugar beet head. *Research in Agricultural Engineering*, 64(4), 143–150. <https://doi.org/10.17221/104/2017-RAE> [in English].

РОЗРОБКА МЕТОДИКИ ТА ЗАСОБІВ ДЛЯ ЕКСПЕРИМЕНТАЛЬНИХ ДОСЛІДЖЕНЬ ПРОЦЕСУ ВИДАЛЕННЯ ГИЧКИ З ГОЛОВОК КОРЕНЕПЛОДІВ НОВИМИ РОБОЧИМИ ОРГАНАМИ

Проведено аналіз методів і технічних засобів, які використовуються для дослідження процесу відокремлення гички та її залишків від головок коренеплодів експериментальними робочими органами. Встановлено, що більшість наявних підходів орієнтована на польові випробування, які є трудомісткими та не завжди дають змогу окремо визначити вплив конструктивних, технологічних і агрофізичних чинників. Тому розроблення лабораторної методики дослідження нових робочих органів є актуальним науково-практичним завданням.

Розроблено лабораторну установку та методику дослідження взаємодії робочих органів із коренеплодами цукрових буряків, що мають різні агрофізичні параметри. Запропонована конструкція дає змогу моделювати основні характеристики посіву: висоту виступання головки коренеплоду над поверхнею ґрунту, відхилення коренеплоду від осі рядка, відстань між суміжними коренеплодами, розмірні параметри коренеплоду та характеристики гички. Установка також забезпечує можливість змінювати параметри роторних робочих органів, зокрема діаметр ротора, довжину й кількість робочих елементів, кут нахилу, кут атаки та частоту обертання.

Методика передбачає фіксацію природних коренеплодів у рамі «рухомого поля», налаштування режимів роботи, високошвидкісну відеозйомку та реєстрацію показників якості після обробки. Зафіксовані параметри дають змогу оцінити пошкодження коренеплодів, висоту й напрям зрізу, якість поверхні зрізу, ступінь відокремлення гички та втрати цукроносною маси. Отримані дані статистично обробляються з використанням середніх значень, стандартного відхилення та



коефіцієнта варіації. Розроблена установка зменшує трудомісткість досліджень і створює основу для обґрунтування раціональних параметрів робочих органів.

Ключові слова: коренеплід, головка коренеплоду, гичка, відокремлення, робочий орган, залишки гички, параметри, експериментальна установка, методика досліджень.

Ф. 5. Рис. 4. Табл. 3. Літ. 11.

INFORMATION ABOUT THE AUTHORS

Andrii BORYS – Candidate of Technical Sciences, Senior Researcher, Head of the Department of Automation of Technological Processes and Equipment in Agro-Industrial Production, Institute of Mechanics and Automation of Agro-Industrial Production of the National Academy of Agrarian Sciences of Ukraine (11/1 Vokzalna St., Hlevakha, Fastiv District, Kyiv Region, 08631, Ukraine, e-mail: aborys@ukr.net, <https://orcid.org/0000-0003-2874-7053>).

Oleksandra TROKHANIAK – Candidate of Technical Sciences, Associate Professor, Associate Professor of the Department of Mechanics, National University of Life and Environmental Sciences of Ukraine (15 Heroiv Oborony St., Kyiv, 03041, Ukraine, e-mail: klendii_o@ukr.net, <https://orcid.org/0000-0002-4671-5824>).

Viktor PRYSYAZHNYI – Candidate of Technical Sciences, Senior Researcher, Institute of Mechanics and Automation of Agro-Industrial Production of the National Academy of Agrarian Sciences of Ukraine (11/1 Vokzalna St., Hlevakha, Fastiv District, Kyiv Region, 08631, Ukraine, e-mail: viktor-pris@ukr.net, <https://orcid.org/0000-0001-5096-3241>).

БОРИС Андрій Миколайович – кандидат технічних наук, старший науковий співробітник, завідувач відділу автоматизації технологічних процесів і техніки в агропромисловому виробництві Інституту механіки та автоматизації агропромислового виробництва Національної академії аграрних наук України (вул. Вокзальна, 11/1, с-ще Глеваха, Фастівський район, Київська область, 08631, Україна, e-mail: aborys@ukr.net, <https://orcid.org/0000-0003-2874-7053>).

ТРОХАНЯК Олександра Миколаївна – кандидат технічних наук, доцент, доцент кафедри механіки Національного університету біоресурсів і природокористування України (вул. Героїв Оборони, 15, м. Київ, 03041, Україна, e-mail: klendii_o@ukr.net, <https://orcid.org/0000-0002-4671-5824>).

ПРИСЯЖНИЙ Віктор Григорович – кандидат технічних наук, старший науковий співробітник Інституту механіки та автоматизації агропромислового виробництва Національної академії аграрних наук України (вул. Вокзальна, 11/1, с-ще Глеваха, Фастівський район, Київська область, 08631, Україна, e-mail: viktor-pris@ukr.net, <https://orcid.org/0000-0001-5096-3241>).